

"900" SERIES SINGLE UNIT DIMENSIONS

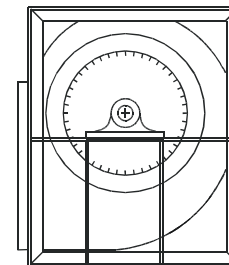
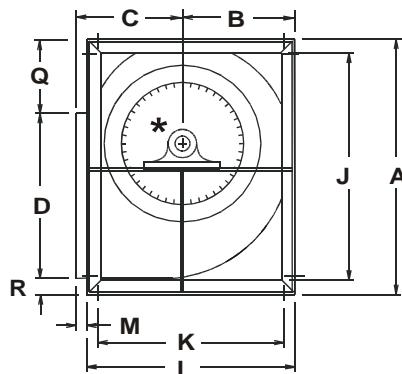
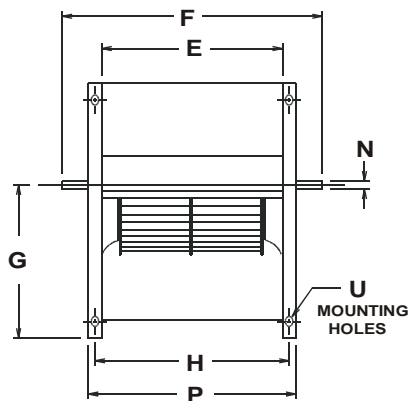

927-936 have double bearing supports

DIMENSIONS (Inches)

MODEL	A	B	C	D	E	See Note F	G	H	J	K	L	M	See Note N	P	Q	R	U	WT. (LBS.)
907	14-3/8	6-7/16	6-1/16	8-1/4	9-3/16	17-3/16	8-5/8	10-3/8	11-5/8	9	11-3/4	3/4	3/4	11-3/8	4-5/8	1-1/2	7/16 x 5/8	28
909-7	17-1/4	7-15/16	7-5/16	10-1/4	9-3/16	17-3/16	10-1/8	10-3/8	14-1/2	11-3/4	14-1/2	3/4	3/4	11-3/8	5-1/2	1-1/2	7/16 x 5/8	34
909	17-1/4	7-15/16	7-5/16	10-1/4	11-13/16	19-13/16	10-1/8	12-15/16	14-1/2	11-3/4	14-1/2	3/4	3/4	13-15/16	5-1/2	1-1/2	7/16 x 5/8	40
910-8	19-1/8	9	8	11-3/8	10-1/2	18-1/2	11-1/4	11-5/8	16-1/2	13-3/8	16-1/4	3/4	3/4	12-5/8	6-1/4	1-1/2	7/16 x 5/8	43
910	19-1/8	9	8	11-3/8	13-1/8	21-5/8	11-1/4	14-1/4	16-1/2	13-3/8	16-1/4	3/4	1	15-1/4	6-1/4	1-1/2	7/16 x 5/8	52
912-9	22-1/4	10-5/8	9-1/8	13-7/16	12-1/4	20-3/4	13	13-3/8	19-5/8	16-1/4	19	3/4	1	14-3/8	7-5/16	1-1/2	7/16 x 5/8	56
912	22-1/4	10-5/8	9-1/8	13-7/16	15-5/8	24-1/8	13	16-3/4	19-5/8	16-1/4	19	3/4	1	17-3/4	7-5/16	1-1/2	7/16 x 5/8	69
# 915-10	26	12-9/16	10-5/16	15-7/8	14-11/16	23-3/16	15-1/4	15-13/16	23-3/8	19-3/8	22-1/8	3/4	1	16-13/16	8-5/8	1-1/2	7/16 x 5/8	72
915	26	12-9/16	10-5/16	15-7/8	18-5/8	27-1/8	15-1/4	19-3/4	23-3/8	19-3/8	22-1/8	3/4	1	20-3/4	8-5/8	1-1/2	7/16 x 5/8	87
918-13	30-3/4	14-15/16	12-3/8	18-7/8	17-3/8	27-1/8	17-3/4	19	29	24-1/2	26-1/2	3/4	1-3/16	20-1/2	10-3/8	1-1/2	7/16 x 5/8	96
918	30-3/4	14-15/16	12-3/8	18-7/8	21-7/8	34	17-3/4	23-1/2	29	24-1/2	26-1/2	3/4	1-3/16	25	10-3/8	1-1/2	7/16 x 5/8	120
920-18	38	18-5/16	14-7/16	24-3/4	22-3/4	35-1/4	22-9/16	24-1/4	32-1/4	25-1/2	31-1/4	1-1/2	1-3/16	26-3/4	11-1/4	2	5/8	212
920	38	18-5/16	14-7/16	24-3/4	24-3/4	37-1/4	22-9/16	26-1/4	32-1/4	25-1/2	31-1/4	1-1/2	1-3/16	28-3/4	11-1/4	2	5/8	220
922	41-1/2	20-1/16	15-11/16	27-1/4	27-1/4	39-3/4	24-5/8	28-3/4	35-3/4	28-1/2	34-1/4	1-1/2	1-3/16	31-1/4	12-1/4	2	5/8	245
925	46-3/4	22-5/8	17-1/4	31-1/4	31-1/4	43-3/4	27-3/4	32-3/4	41	32-3/4	38-3/8	1-1/2	1-3/16	35-1/4	13-1/2	2	5/8	297
927	51-1/2	25-1/16	19-1/8	34-1/4	34-1/4	50-1/4	30-1/4	35-3/4	46-1/2	37-11/16	42-11/16	1-1/2	1-11/16	38-1/4	15-1/4	2	5/8	385
930	55-1/2	27-1/16	20-5/16	36-3/4	36-3/4	52-3/4	32-5/8	38-1/4	50-1/2	40-7/8	45-7/8	1-1/2	1-11/16	40-3/4	16-3/4	2	5/8	470
933	59-3/4	29-1/8	24-5/8	42-15/16	39-3/4	58-3/4	34-1/4	41-3/4	54-3/4	47-1/4	52-1/4	1-1/2	2-3/16	43-3/4	14-13/16	2	5/8	590
936	59-3/4	29-1/8	24-5/8	42-15/16	42-3/4	61-3/4	34-1/4	44-3/4	54-3/4	47-1/4	52-1/4	1-1/2	2-3/16	46-3/4	14-13/16	2	5/8	640

"900-2" SERIES TWIN UNIT DIMENSIONS

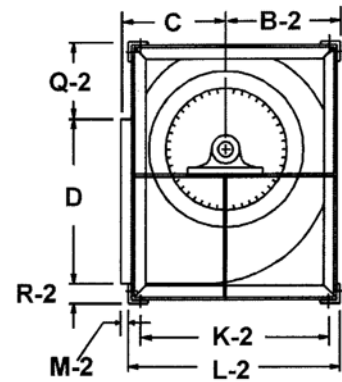
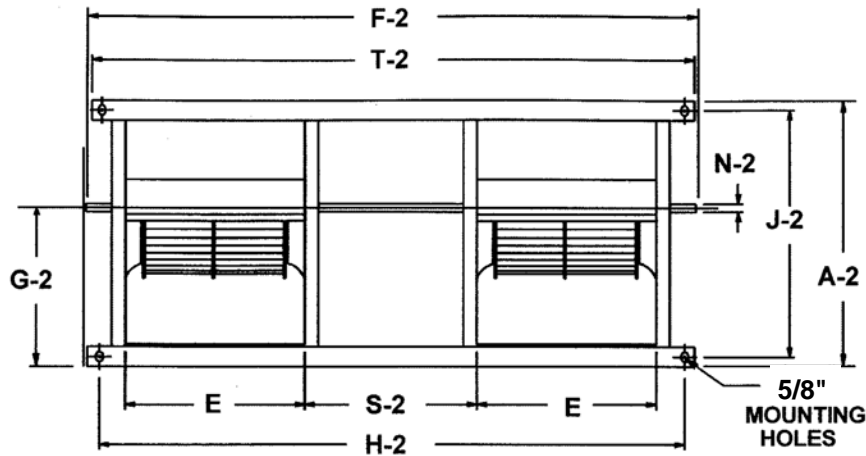

DIMENSIONS (Inches)

MODEL	A-2	B-2	C	D	E	See Note F-2	G-2	H-2	J-2	K-2	L-2	M-2	See Note N-2	T-2	Q-2	R-2	S-2	Wt. (lbs)
907-2	14-3/4	6-5/8	6-1/16	8-1/4	9-3/16	33-3/8	8-13/16	30-5/8	13-1/4	10-5/8	12-1/8	9/16	3/4	32-3/8	4-13/16	1-11/16	7	70
909-7-2	17-5/8	8-1/8	7-5/16	10-1/4	9-3/16	33-3/8	10-5/16	30-5/8	16-1/8	13-3/8	14-7/8	9/16	3/4	32-3/8	5-11/16	1-11/16	7	90
909-2	17-5/8	8-1/8	7-5/16	10-1/4	11-13/16	40-5/8	10-5/16	36-5/8	16-1/8	13-3/8	14-7/8	9/16	3/4	38-3/8	5-11/16	1-11/16	9	120
910-8-2	19-1/2	9-3/16	8	11-3/8	10-1/2	37	11-7/16	34-1/4	18	15-1/8	16-5/8	9/16	3/4	36	6-7/16	1-11/16	8	135
910-2	19-1/2	9-3/16	8	11-3/8	13-1/8	44-3/4	11-7/16	40-1/4	18	15-1/8	16-5/8	9/16	1	42	6-7/16	1-11/16	10	145
912-9-2	22-5/8	10-13/16	9-1/8	13-7/16	12-1/4	42	13-3/16	38-3/4	21-1/8	17-7/8	19-3/8	9/16	1	40-1/2	7-1/2	1-11/16	9	173
912-2	22-5/8	10-13/16	9-1/8	13-7/16	15-5/8	51-3/4	13-3/16	47-1/4	21-1/8	17-7/8	19-3/8	9/16	1	49	7-1/2	1-11/16	12	175
# 915-10-2	26-3/8	12-3/4	10-5/16	15-7/8	14-11/16	52-3/8	15-5/16	46-5/8	24-7/8	21	22-1/2	9/16	1-3/16	48-3/8	8-13/16	1-11/16	12	190
915-2	26-3/8	12-3/4	10-5/16	15-7/8	18-5/8	63-3/8	15-5/16	56-1/4	24-7/8	21	22-1/2	9/16	1-3/16	58	8-13/16	1-11/16	15	200
918-13-2	31-1/8	15-3/16	12-3/8	18-7/8	17-3/8	60-3/4	17-15/16	52-3/4	29-5/8	25-1/2	27	9/16	1-3/16	54-1/2	10-1/2	1-3/4	13	242
918-2	31-1/8	15-3/16	12-3/8	18-7/8	21-7/8	74-3/4	18	66-3/4	29-5/8	25-1/2	27	9/16	1-3/16	68-1/2	10-1/2	1-3/4	18	325
920-18-2	38-1/2	18-9/16	14-7/16	24-3/4	22-3/4	83-1/2	22-3/4	69-3/4	36-1/2	29-3/4	31-3/4	1-1/4	1-15/16	71-1/2	11-1/2	2-1/4	18	530
920-2	38-1/2	18-9/16	14-7/16	24-3/4	24-3/4	89-1/2	22-13/16	75-3/4	36-1/2	29-3/4	31-3/4	1-1/4	1-15/16	77-1/2	11-1/2	2-1/4	20	600
922-2	42	20-5/16	15-11/16	27-1/4	27-1/4	96-1/2	24-7/8	82-3/4	40	32-3/4	34-3/4	1-1/4	1-15/16	84-1/2	12-1/2	2-1/4	22	677
925-2	47-1/4	22-7/8	17-1/4	31-1/4	31-1/4	108	28	93-3/4	45-1/4	36-7/8	38-7/8	1-1/4	2-3/16	95-1/2	13-3/4	2-1/4	25	827
927-2	52	25-5/16	19-1/8	34-1/4	34-1/4	116	30-1/2	102-1/4	50	41-3/16	43-3/16	1-1/4	2-7/16	104	15-1/2	2-1/4	27-1/2	900
930-2	56	27-5/16	20-5/16	36-3/4	36-3/4	123-1/2	32-7/8	109-3/4	54	45-3/8	46-3/8	1-1/4	2-11/16	111-1/2	17	2-1/4	30	1070
933-2	60-1/4	29-3/8	24-5/8	42-15/16	39-3/4	132-1/2	34-1/2	118-3/4	58-1/4	50-3/4	52-3/4	1-1/4	2-11/16	120-1/2	15-1/16	2-1/4	33	1400
936-2	60-1/4	29-3/8	24-5/8	42-15/16	42-3/4	141-1/2	34-1/2	127-3/4	58-1/4	50-3/4	52-3/4	1-1/4	2-11/16	129-1/2	15-1/16	2-1/4	36	1440

Model G7-5		<u>SHAFT DIAMETER</u> 3/4"						<u>MAXIMUM BHP</u> 3/4									
CFM	OUTLET VELOCITY FPM	1/8" SP		1/4" SP		1/2" SP		3/4" SP		1" SP		1-1/2" SP		2" SP		2-1/2" SP	
		RPM	BHP	RPM	BHP	RPM	BHP	RPM	BHP	RPM	BHP	RPM	BHP	RPM	BHP	RPM	BHP
200	507	575	0.01	747	0.01	1053	0.03	1288	0.04	1482	0.06	1801	0.10	2066	0.13	2298	0.17
300	761	704	0.02	836	0.03	1062	0.04	1290	0.06	1490	0.08	1824	0.13	2100	0.18	2339	0.23
400	1015	821	0.04	966	0.06	1151	0.07	1318	0.09	1495	0.11	1824	0.16	2107	0.22	2356	0.28
500	1269	944	0.07	1085	0.09	1282	0.12	1422	0.14	1553	0.16	1833	0.21	2107	0.27	2355	0.33
600	1523	1077	0.11	1202	0.14	1408	0.18	1554	0.21	1672	0.24	1891	0.29	2124	0.35	2358	0.41
700	1777	1215	0.17	1326	0.20	1527	0.25	1682	0.29	1804	0.33	2003	0.39	2190	0.45	2388	0.52
800	2031	1356	0.24	1458	0.27	1643	0.34	1803	0.39	1932	0.44	2133	0.52	2302	0.59	2466	0.66
900	2284	1499	0.33	1594	0.37	1763	0.44	1920	0.51	2053	0.57	2265	0.68	-	-	-	-
1000	2538	1644	0.44	1733	0.49	1889	0.57	2036	0.65	2171	0.72	-	-	-	-	-	-

Model G7 & 907		<u>SHAFT DIAMETER</u> 3/4" 3/4" *						<u>MAXIMUM BHP</u> 3/4 3									
CFM	OUTLET VELOCITY FPM	1/8" SP		1/4" SP		1/2" SP		3/4" SP		1" SP		1-1/2" SP		2" SP		2-1/2" SP	
		RPM	BHP	RPM	BHP	RPM	BHP	RPM	BHP	RPM	BHP	RPM	BHP	RPM	BHP	RPM	BHP
400	759	521	0.02	681	0.03	962	0.07	1180	0.12	1361	0.16	1657	0.27	1902	0.38	2119	0.51
500	949	573	0.03	709	0.05	958	0.08	1178	0.14	1363	0.19	1667	0.31	1920	0.43	2136	0.56
600	1139	638	0.05	752	0.07	970	0.11	1175	0.15	1360	0.22	1669	0.35	1926	0.48	2150	0.63
700	1329	709	0.07	806	0.10	1000	0.14	1181	0.18	1356	0.24	1666	0.38	1927	0.54	2155	0.69
800	1519	781	0.10	870	0.13	1041	0.18	1206	0.23	1362	0.28	1663	0.42	1924	0.59	2154	0.76
900	1709	856	0.14	938	0.16	1090	0.22	1241	0.28	1386	0.34	1658	0.45	1922	0.63	2151	0.82
1000	1899	932	0.18	1010	0.21	1146	0.28	1284	0.34	1418	0.40	1672	0.53	1917	0.68	2149	0.88
1100	2089	1010	0.23	1082	0.26	1209	0.33	1334	0.41	1458	0.48	1696	0.62	1921	0.75	2144	0.94
1200	2279	1088	0.30	1156	0.33	1276	0.40	1389	0.49	1505	0.56	1728	0.71	1940	0.87	2143	1.02
1300	2469	1168	0.37	1231	0.41	1346	0.48	1451	0.57	1556	0.66	1766	0.82	1967	0.99	2160	1.15
1400	2659	1248	0.46	1308	0.50	1418	0.57	1516	0.66	1612	0.76	1810	0.94	2001	1.12	2184	1.30
1500	2849	1328	0.56	1385	0.60	1490	0.68	1584	0.77	1674	0.88	1858	1.08	2039	1.27	2214	1.46
1600	3039	1409	0.67	1463	0.72	1563	0.80	1654	0.89	1739	1.00	1909	1.23	2082	1.43	2249	1.63
1700	3229	1490	0.79	1542	0.85	1637	0.94	1726	1.03	1807	1.14	1966	1.38	2129	1.60	2289	1.81
1800	3419	1572	0.94	1621	0.99	1712	1.09	1798	1.19	1876	1.29	2027	1.54	2180	1.79	2333	2.02
1900	3609	1654	1.09	1700	1.15	1788	1.26	1871	1.36	1948	1.47	2091	1.72	2233	2.00	2380	2.24
2000	3799	1736	1.27	1780	1.33	1865	1.45	1944	1.55	2020	1.66	2157	1.92	2293	2.21	2430	2.47

Model G9-7 & 909-7		<u>SHAFT DIAMETER</u> 3/4" 3/4" *						<u>MAXIMUM BHP</u> 3/4 3									
CFM	OUTLET VELOCITY FPM	1/8" SP		1/4" SP		1/2" SP		3/4" SP		1" SP		1-1/2" SP		2" SP		2-1/2" SP	
		RPM	BHP	RPM	BHP	RPM	BHP	RPM	BHP	RPM	BHP	RPM	BHP	RPM	BHP	RPM	BHP
500	764	370	0.02	507	0.04	735	0.07	913	0.11	1063	0.16	1310	0.24	1516	0.33	1695	0.43
625	955	391	0.03	514	0.05	722	0.09	898	0.14	1049	0.19	1301	0.29	1510	0.40	1692	0.51
750	1146	424	0.05	528	0.07	718	0.11	885	0.16	1033	0.22	1287	0.34	1499	0.46	1684	0.59
875	1337	467	0.07	550	0.09	727	0.14	878	0.19	1021	0.25	1272	0.38	1485	0.52	1672	0.67
1000	1529	513	0.10	582	0.12	739	0.18	884	0.23	1014	0.29	1257	0.43	1470	0.59	1658	0.75
1125	1720	562	0.14	621	0.16	757	0.22	895	0.28	1019	0.34	1247	0.49	1454	0.65	1642	0.82
1250	1911	613	0.18	664	0.21	781	0.27	909	0.34	1029	0.41	1242	0.55	1443	0.72	1627	0.90
1375	2102	665	0.24	711	0.27	813	0.33	926	0.40	1041	0.48	1248	0.63	1435	0.79	1616	0.99
1500	2293	718	0.30	759	0.33	849	0.40	949	0.47	1057	0.55	1257	0.72	1436	0.89	1607	1.08
1625	2484	771	0.38	809	0.41	889	0.49	980	0.56	1075	0.64	1269	0.82	1443	1.00	1604	1.19
1750	2675	825	0.47	860	0.51	933	0.58	1014	0.66	1100	0.74	1283	0.94	1453	1.13	1609	1.32
1875	2867	880	0.57	912	0.61	979	0.69	1051	0.78	1131	0.86	1300	1.06	1465	1.27	1618	1.46
2000	3058	934	0.69	964	0.73	1027	0.81	1092	0.90	1165	1.00	1319	1.18	1479	1.42	1629	1.63
2125	3249	989	0.82	1017	0.86	1075	0.95	1136	1.05	1201	1.15	1344	1.34	1495	1.57	1641	1.81
2250	3440	1044	0.97	1070	1.01	1125	1.11	1182	1.20	1241	1.31	1374	1.52	1513	1.74	1655	2.00
2375	3631	1099	1.14	1124	1.18	1175	1.28	1229	1.38	1284	1.49	1406	1.71	1534	1.92	1672	2.20
2500	3822	1154	1.32	1178	1.37	1227	1.47	1277	1.57	1329	1.69	1441	1.92	1562	2.15	1690	2.41

Model G9, 809 & 909		<u>SHAFT DIAMETER</u> 3/4" 3/4" * 3/4" *						<u>MAXIMUM BHP</u> 3/4 3 3									
CFM	OUTLET VELOCITY FPM	1/8" SP		1/4" SP		1/2" SP		3/4" SP		1" SP		1-1/2" SP		2" SP		2-1/2" SP	
		RPM	BHP	RPM	BHP	RPM	BHP	RPM	BHP	RPM	BHP	RPM	BHP	RPM	BHP	RPM	BHP
750	891	392	0.04	531	0.06	780	0.13	965	0.21	1112	0.28	1347	0.45	1541	0.63	1709	0.83
875	1040	410	0.05	537	0.08	757	0.14	960	0.23	1115	0.32	1359	0.49	1557	0.70	1728	0.91
1000	1189	438	0.07	547	0.10	749	0.16	943	0.25	1109	0.36	1365	0.55	1568	0.75	1743	0.99
1125	1337	471	0.10	562	0.12	754	0.19	918	0.27	1094	0.39	1364	0.61	1575	0.83	1754	1.06
1250	1486	506	0.13	583	0.16	760	0.23	918	0.31	1067	0.40	1357	0.67	1576	0.91	1761	1.15
1375	1635	543	0.16	611	0.19	770	0.27	923	0.35	1059	0.45	1341	0.71	1572	0.99	1763	1.26
1500	1783	581	0.21	642	0.24	783	0.32	929	0.41	1062	0.50	1315	0.74	1561	1.05	1759	1.35
1625	1932	621	0.26	675	0.29	799	0.37	938	0.47	1067	0.56	1298	0.78	1542	1.10	1750	1.44
1750	2081	661	0.32	710	0.35	821	0.43	950	0.53	1074	0.64	1298	0.86	1514	1.14	1735	1.51
1875	2229	702	0.39	746	0.42	848	0.50	964	0.60	1083	0.72	1302	0.95	1498	1.21	1712	1.57
2000	2378	744	0.46	784	0.50	877	0.58	980	0.68	1094	0.80	1308	1.04	1499	1.31	1680	1.60
2125	2527	785	0.55	823	0.59	908	0.67	1002	0.77	1108	0.90	1315	1.16	1502	1.42	1675	1.71
2250	2675	828	0.64	863	0.70	941	0.77	1028	0.88	1124	1.00	1323	1.27	1507	1.54	1676	1.85
2375	2824	870	0.75	902	0.81	976	0.89	1056	0.99	1142	1.11	1333	1.40	1513	1.68	1679	1.99
2500	2973	912	0.87	943	0.93	1011	1.01	1087	1.12	1166	1.24	1346	1.53	1521	1.84	1684	2.13
2625	3121	955	1.00	984	1.07	1048	1.15	1118	1.26	1193	1.38	1360	1.67	1530	2.00	1690	2.31
2750	3270	998	1.14	1025	1.21	1085	1.30	1152	1.42	1221	1.54	1376	1.83	1540	2.16	1698	2.50
2875	3419	1041	1.30	1067	1.37	1124	1.48	1186	1.58	1252	1.71	1393	1.99	1553	2.34	1706	2.69
3000	3567	1084	1.47	1109	1.54	1162	1.67	1221	1.76	1283	1.90	1416	2.18	1567	2.53	1716	2.90

Model G10-8 & 910-8

**G10-8
910-8**

SHAFT DIAMETER

3/4"
3/4" *

MAXIMUM BHP

3/4
3

CFM	OUTLET VELOCITY		1/8" SP		1/4" SP		1/2" SP		3/4" SP		1" SP		1-1/2" SP		2" SP		2-1/2" SP	
	FPM	RPM	BHP	RPM	BHP	RPM	BHP	RPM	BHP	RPM	BHP	RPM	BHP	RPM	BHP	RPM	BHP	RPM
750	904	352	0.04	466	0.06	665	0.10	837	0.16	975	0.22	1197	0.33	1381	0.44	1543	0.55	
875	1054	372	0.05	476	0.08	652	0.12	822	0.18	966	0.25	1195	0.39	1383	0.51	1545	0.64	
1000	1205	402	0.07	490	0.10	656	0.15	798	0.20	950	0.28	1189	0.44	1381	0.59	1546	0.73	
1125	1356	435	0.10	506	0.12	664	0.18	799	0.24	927	0.30	1177	0.48	1375	0.66	1544	0.83	
1250	1507	470	0.13	529	0.15	675	0.22	804	0.29	922	0.35	1160	0.52	1365	0.72	1538	0.91	
1375	1657	507	0.17	559	0.19	688	0.26	813	0.33	926	0.41	1136	0.55	1350	0.78	1528	0.99	
1500	1808	545	0.22	591	0.24	703	0.30	823	0.38	932	0.47	1129	0.62	1330	0.83	1514	1.07	
1625	1959	583	0.27	625	0.30	721	0.35	836	0.44	941	0.53	1132	0.71	1304	0.86	1496	1.13	
1750	2109	622	0.33	660	0.37	745	0.42	850	0.51	952	0.60	1137	0.80	1304	0.97	1472	1.18	
1875	2260	661	0.41	696	0.44	773	0.50	867	0.58	965	0.68	1144	0.89	1307	1.09	1457	1.27	
2000	2411	700	0.49	734	0.52	804	0.59	884	0.65	980	0.77	1153	0.99	1312	1.20	1458	1.41	
2125	2562	740	0.58	772	0.62	837	0.69	908	0.76	995	0.86	1165	1.09	1318	1.33	1462	1.55	
2250	2712	779	0.69	810	0.73	870	0.81	936	0.87	1012	0.96	1177	1.20	1327	1.46	1467	1.70	
2375	2863	819	0.80	849	0.84	905	0.93	966	1.00	1032	1.07	1191	1.33	1338	1.59	1474	1.85	
2500	3014	859	0.93	887	0.97	941	1.07	998	1.15	1059	1.22	1206	1.46	1349	1.73	1483	2.01	
2625	3164	899	1.07	926	1.12	977	1.21	1031	1.30	1087	1.38	1222	1.60	1362	1.89	1493	2.18	
2750	3315	940	1.22	966	1.28	1014	1.38	1064	1.48	1118	1.56	1239	1.75	1376	2.06	1504	2.36	
2875	3466	980	1.39	1005	1.45	1052	1.55	1099	1.66	1149	1.75	1257	1.91	1391	2.23	1517	2.54	
3000	3616	1020	1.57	1044	1.64	1089	1.74	1134	1.86	1182	1.95	1283	2.13	1407	2.42	1530	2.75	

Model G10, 810 & 910

**G10
810
910**

SHAFT DIAMETER

3/4"
3/4"
1" *

MAXIMUM BHP

3/4
3
5

CFM	OUTLET VELOCITY		1/8" SP		1/4" SP		1/2" SP		3/4" SP		1" SP		1-1/2" SP		2" SP		2-1/2" SP	
	FPM	RPM	BHP	RPM	BHP	RPM	BHP	RPM	BHP	RPM	BHP	RPM	BHP	RPM	BHP	RPM	BHP	RPM
1000	964	358	0.06	476	0.09	688	0.18	863	0.28	997	0.38	1210	0.58	1383	0.79	1533	1.03	
1125	1085	373	0.07	483	0.10	662	0.18	855	0.31	997	0.43	1218	0.65	1395	0.87	1548	1.10	
1250	1205	389	0.09	491	0.13	665	0.21	838	0.33	992	0.46	1222	0.72	1404	0.97	1559	1.21	
1375	1326	407	0.11	503	0.15	671	0.24	811	0.33	979	0.49	1222	0.78	1410	1.06	1568	1.33	
1500	1446	426	0.13	517	0.18	678	0.27	814	0.37	957	0.51	1216	0.84	1412	1.15	1575	1.45	
1625	1567	446	0.16	532	0.21	685	0.30	819	0.41	937	0.53	1206	0.88	1410	1.23	1578	1.56	
1750	1687	468	0.19	548	0.25	694	0.35	825	0.46	941	0.58	1189	0.92	1404	1.30	1578	1.66	
1875	1808	491	0.23	566	0.29	704	0.40	832	0.51	946	0.63	1164	0.93	1393	1.36	1574	1.76	
2000	1929	515	0.27	584	0.33	717	0.45	840	0.56	952	0.70	1148	0.97	1376	1.41	1566	1.84	
2125	2049	539	0.32	603	0.38	731	0.50	848	0.63	958	0.76	1151	1.05	1353	1.43	1554	1.92	
2250	2170	563	0.37	623	0.43	746	0.57	858	0.70	966	0.83	1156	1.13	1325	1.45	1536	1.97	
2375	2290	588	0.43	644	0.49	762	0.64	870	0.78	974	0.91	1162	1.22	1327	1.55	1513	2.01	
2500	2411	613	0.49	667	0.56	779	0.71	883	0.86	983	1.01	1168	1.32	1331	1.66	1482	2.01	
2625	2531	639	0.56	689	0.63	796	0.79	898	0.94	993	1.10	1175	1.42	1336	1.77	1483	2.14	
2750	2652	665	0.64	713	0.71	814	0.88	913	1.04	1005	1.20	1183	1.52	1342	1.88	1487	2.27	
2875	2772	691	0.72	737	0.80	833	0.97	929	1.14	1019	1.31	1191	1.64	1348	2.02	1491	2.41	
3000	2893	717	0.81	761	0.89	852	1.07	945	1.25	1033	1.42	1199	1.78	1355	2.15	1497	2.55	
3125	3014	743	0.91	785	0.99	872	1.17	962	1.36	1048	1.54	1209	1.92	1362	2.29	1503	2.70	
3250	3134	770	1.01	810	1.10	892	1.29	980	1.49	1064	1.68	1220	2.06	1370	2.43	1509	2.86	
3375	3255	796	1.13	835	1.22	914	1.41	998	1.62	1080	1.82	1232	2.22	1379	2.60	1516	3.03	
3500	3375	823	1.25	860	1.35	936	1.54	1017	1.75	1096	1.96	1245	2.37	1387	2.79	1524	3.21	
3625	3496	849	1.38	886	1.48	959	1.68	1036	1.90	1114	2.12	1259	2.54	1397	2.98	1531	3.38	
3750	3616	876	1.52	911	1.63	982	1.83	1056	2.05	1131	2.28	1274	2.72	1408	3.17	1540	3.59	
3875	3737	903	1.68	937	1.78	1005	1.99	1076	2.22	1149	2.46	1289	2.91	1420	3.37	1548	3.83	
4000	3858	931	1.84	963	1.94	1029	2.16	1096	2.39	1168	2.64	1305	3.11	1433	3.58	1557	4.07	

Model G12-9 & 912-9

**G12-9
912-9**

SHAFT DIAMETER

3/4"
1" *

MAXIMUM BHP

2
5

CFM	OUTLET VELOCITY		1/8" SP		1/4" SP		1/2" SP		3/4" SP		1" SP		1-1/2" SP		2" SP		2-1/2" SP	
	FPM	RPM	BHP	RPM	BHP	RPM	BHP	RPM	BHP	RPM	BHP	RPM	BHP	RPM	BHP	RPM	BHP	RPM
1400	1224	350	0.11	430	0.14	581	0.22	703	0.30	818	0.39	1049	0.66	1231	0.95	1382	1.25	
1600	1399	381	0.15	445	0.18	590	0.28	707	0.37	812	0.46	1014	0.68	1214	1.02	1375	1.35	
1800	1574	416	0.21	470	0.24	599	0.34	716	0.44	815	0.54	999	0.76	1181	1.04	1356	1.42	
2000	1749	452	0.27	498	0.31	610	0.40	724	0.53	823	0.64	995	0.86	1156	1.11	1323	1.46	
2200	1924	490	0.36	529	0.39	622	0.47	733	0.62	831	0.75	998	0.99	1150	1.25	1294	1.53	
2400	2099	528	0.46	563	0.50	646	0.58	744	0.71	840	0.86	1005	1.13	1149	1.40	1287	1.69	
2600	2274	567	0.57	598	0.62	672	0.71	756	0.82	850	0.99	1014	1.29	1154	1.58	1284	1.87	
2800	2449	606	0.70	634	0.76	700	0.85	774	0.95	861	1.12	1023	1.46	1162	1.77	1287	2.09	
3000	2624	646	0.86	671	0.91	730	1.02	799	1.13	872	1.25	1032	1.64	1171	1.99	1293	2.32	
3200	2799	686	1.03	709	1.10	763	1.20	825	1.32	890	1.43	1042	1.83	1179	2.21	1303	2.57	
3400	2974	726	1.22	747	1.30	797	1.41	853	1.54	914	1.66	1052	2.02	1188	2.45	1311	2.84	
3600	3149	766	1.44	786	1.52	832	1.65	883	1.77	940	1.91	1064	2.23	1198	2.69	1319	3.13	
3800	3324	807	1.69	825	1.77	868	1.91	914	2.04	967	2.18	1077	2.45	1208	2.95	1328	3.42	
4000	3499	847	1.96	865	2.05	904	2.20	948	2.33	996	2.48	1099	2.77	1219	3.21	1338	3.73	
4200	3674	888	2.26	905	2.35	942	2.52	982	2.65	1026	2.80	1124	3.11	1231	3.49	1348	4.04	
4400	3849	929	2.59	945	2.69	979	2.86	1017	3.01	1057	3.16	1150	3.49	1244	3.79	1359	4.37	
4600	4024	970	2.95	985	3.05	1017	3.25	1053	3.40	1091	3.55	1177	3.89	1267	4.22	1371	4.71	

Model G12, 812 & 912

G12
812
912

SHAFT DIAMETER

3/4"
1"
1" *

MAXIMUM BHP

2
3
5

CFM	OUTLET VELOCITY FPM	1/8" SP		1/4" SP		1/2" SP		3/4" SP		1" SP		1-1/2" SP		2" SP		2-1/2" SP	
		RPM	BHP	RPM	BHP	RPM	BHP	RPM	BHP	RPM	BHP	RPM	BHP	RPM	BHP	RPM	BHP
1500	1028	320	0.09	418	0.12	580	0.21	718	0.31	836	0.41	1057	0.68	1246	1.00	1400	1.31
1750	1200	343	0.12	428	0.16	581	0.26	710	0.36	829	0.48	1027	0.73	1217	1.06	1387	1.42
2000	1371	370	0.17	444	0.21	587	0.32	711	0.43	821	0.55	1020	0.81	1187	1.11	1353	1.48
2250	1543	401	0.23	464	0.28	596	0.39	714	0.51	820	0.64	1011	0.92	1180	1.22	1327	1.56
2500	1714	436	0.30	488	0.36	607	0.47	720	0.60	823	0.74	1004	1.03	1171	1.36	1319	1.69
2750	1886	471	0.39	514	0.45	622	0.57	729	0.71	828	0.86	1004	1.17	1163	1.50	1311	1.87
3000	2057	507	0.50	544	0.56	641	0.69	740	0.83	835	0.99	1007	1.32	1159	1.67	1302	2.04
3250	2228	544	0.62	577	0.69	663	0.83	754	0.97	845	1.14	1011	1.50	1160	1.85	1296	2.24
3500	2400	581	0.77	611	0.84	687	0.99	771	1.14	857	1.30	1018	1.68	1163	2.07	1296	2.46
3750	2571	618	0.93	646	1.01	712	1.17	791	1.34	870	1.49	1026	1.88	1168	2.31	1298	2.71
4000	2743	656	1.12	682	1.20	739	1.37	814	1.55	887	1.72	1036	2.11	1174	2.55	1302	3.00
4250	2914	694	1.34	718	1.42	770	1.59	837	1.79	907	1.97	1047	2.36	1182	2.81	1307	3.29
4500	3086	732	1.58	755	1.66	803	1.84	863	2.05	929	2.25	1060	2.62	1191	3.10	1313	3.60
4750	3257	770	1.84	792	1.93	837	2.12	889	2.33	952	2.55	1076	2.95	1202	3.42	1321	3.92
5000	3429	809	2.14	829	2.23	871	2.43	917	2.65	976	2.88	1095	3.31	1214	3.76	1330	4.28

Model G15-10 & 915-10

G15-10
915-10

SHAFT DIAMETER

1"
1" *

MAXIMUM BHP

2
5

CFM	OUTLET VELOCITY FPM	1/8" SP		1/4" SP		1/2" SP		3/4" SP		1" SP		1-1/2" SP		2" SP		2-1/2" SP	
		RPM	BHP	RPM	BHP	RPM	BHP	RPM	BHP	RPM	BHP	RPM	BHP	RPM	BHP	RPM	BHP
1500	926	252	0.07	324	0.11	461	0.20	572	0.30	664	0.40	820	0.66	948	0.94	1060	1.24
1750	1080	276	0.10	332	0.14	457	0.23	567	0.34	661	0.47	816	0.72	946	1.03	1060	1.35
2000	1235	303	0.14	347	0.18	456	0.27	561	0.39	655	0.53	811	0.80	942	1.10	1058	1.45
2250	1389	329	0.20	367	0.23	460	0.33	558	0.44	649	0.58	807	0.90	938	1.20	1053	1.55
2500	1543	355	0.26	393	0.30	471	0.40	559	0.52	646	0.65	801	0.98	934	1.33	1049	1.67
2750	1698	381	0.33	420	0.38	486	0.48	563	0.60	644	0.74	795	1.07	929	1.45	1045	1.83
3000	1852	408	0.42	446	0.48	503	0.58	573	0.71	647	0.85	791	1.18	923	1.57	1040	1.98
3250	2007	434	0.52	472	0.59	526	0.69	587	0.82	653	0.97	789	1.29	916	1.68	1034	2.13
3500	2161	461	0.63	499	0.71	552	0.83	604	0.96	664	1.11	790	1.44	913	1.83	1027	2.27
3750	2315	488	0.76	525	0.85	579	0.98	623	1.11	678	1.27	794	1.61	911	1.98	1023	2.44
4000	2470	514	0.90	551	1.01	605	1.16	646	1.29	694	1.44	800	1.79	912	2.18	1020	2.62
4250	2624	542	1.07	578	1.18	632	1.35	672	1.49	713	1.64	811	2.00	915	2.40	1019	2.81
4500	2779	570	1.25	604	1.38	658	1.57	699	1.72	734	1.86	825	2.24	920	2.64	1020	3.07
4750	2933	598	1.45	631	1.59	684	1.80	726	1.97	759	2.12	840	2.49	929	2.90	1023	3.36
5000	3087	626	1.68	657	1.83	710	2.06	752	2.24	786	2.40	857	2.77	941	3.20	1028	3.65
5250	3242	654	1.93	684	2.09	737	2.34	778	2.54	813	2.71	876	3.07	955	3.51	1036	3.97
5500	3396	683	2.20	711	2.37	763	2.65	804	2.87	840	3.05	898	3.41	971	3.85	1048	4.33

Model G15, 815 & 915

G15
815
915

SHAFT DIAMETER

1"
1"
1" *

MAXIMUM BHP

3
3
5

CFM	OUTLET VELOCITY FPM	1/8" SP		1/4" SP		1/2" SP		3/4" SP		1" SP		1-1/2" SP		2" SP		2-1/2" SP	
		RPM	BHP	RPM	BHP	RPM	BHP	RPM	BHP	RPM	BHP	RPM	BHP	RPM	BHP	RPM	BHP
2000	974	287	0.10	370	0.15	503	0.26	625	0.38	726	0.50	888	0.74	1019	0.97	1132	1.20
2250	1095	300	0.13	378	0.18	507	0.30	619	0.43	723	0.56	890	0.83	1025	1.11	1140	1.37
2500	1217	316	0.16	389	0.22	514	0.34	616	0.48	717	0.63	889	0.93	1027	1.23	1145	1.53
2750	1339	332	0.20	401	0.27	521	0.40	621	0.54	713	0.70	886	1.03	1028	1.36	1148	1.70
3000	1461	349	0.25	415	0.32	528	0.46	627	0.61	713	0.78	880	1.13	1026	1.50	1149	1.86
3250	1582	368	0.31	429	0.38	537	0.54	635	0.69	719	0.86	875	1.24	1021	1.63	1148	2.02
3500	1704	387	0.38	445	0.45	548	0.62	642	0.78	726	0.96	872	1.35	1016	1.77	1145	2.19
3750	1826	407	0.45	461	0.53	560	0.71	650	0.89	733	1.06	875	1.47	1011	1.91	1139	2.36
4000	1948	429	0.54	477	0.62	574	0.81	659	1.00	740	1.19	881	1.59	1007	2.05	1134	2.53
4250	2069	451	0.64	494	0.72	587	0.92	670	1.12	748	1.32	888	1.73	1009	2.20	1129	2.70
4500	2191	473	0.75	513	0.83	601	1.04	682	1.25	756	1.46	895	1.89	1014	2.37	1126	2.89
4750	2313	495	0.87	532	0.96	616	1.17	695	1.39	767	1.62	902	2.07	1020	2.55	1128	3.08
5000	2435	518	1.00	552	1.09	632	1.31	708	1.55	778	1.79	909	2.26	1028	2.74	1133	3.29
5250	2556	541	1.15	572	1.25	648	1.47	722	1.72	790	1.97	917	2.46	1035	2.96	1139	3.51
5500	2678	564	1.31	593	1.41	664	1.64	736	1.89	803	2.16	926	2.68	1042	3.20	1146	3.75
5750	2800	587	1.49	615	1.59	681	1.83	751	2.09	816	2.36	936	2.91	1049	3.45	1154	4.00
6000	2922	610	1.69	636	1.79	699	2.03	766	2.30	830	2.58	947	3.16	1057	3.72	1161	4.29
6250	3043	634	1.90	659	2.01	717	2.25	782	2.52	844	2.82	959	3.41	1066	4.01	1168	4.59
6500	3165	657	2.13	681	2.24	736	2.49	799	2.77	859	3.07	971	3.69	1075	4.31	1175	4.91
6750	3287	681	2.37	703	2.49	755	2.74	815	3.03	874	3.34	984	3.98	1086	4.62	--	--
7000	3409	704	2.64	726	2.76	775	3.01	832	3.31	890	3.62	998	4.29	1097	4.95	--	--
7250	3530	728	2.92	749	3.04	795	3.31	849	3.60	906	3.93	1011	4.62	--	--	--	--
7500	3652	752	3.23	772	3.35	815	3.62	867	3.92	922	4.25	1025	4.96	--	--	--	--

Model G18-13 & 918-13

STANDARD SHAFTS SHOWN
LARGER SIZES AVAILABLE - 900's

G18-13
918-13

SHAFT DIAMETER
1"
1-3/16"

MAXIMUM BHP
5
10

CFM	OUTLET VELOCITY FPM	1/8" SP		1/2" SP		1" SP		1-1/2" SP		2" SP		2-1/2" SP		3" SP		4" SP	
		RPM	BHP	RPM	BHP	RPM	BHP	RPM	BHP	RPM	BHP	RPM	BHP	RPM	BHP	RPM	BHP
3000	1317	238	0.23	381	0.43	560	0.80	707	1.22	820	1.64	916	2.07	1000	2.51	1146	3.43
3500	1536	265	0.34	385	0.56	539	0.93	694	1.41	816	1.90	917	2.38	1005	2.88	1156	3.90
4000	1756	290	0.48	391	0.71	538	1.11	671	1.59	803	2.15	911	2.71	1003	3.26	1160	4.39
4500	1975	315	0.65	403	0.91	542	1.34	658	1.81	780	2.38	897	3.02	996	3.65	1159	4.90
5000	2195	341	0.85	425	1.17	546	1.60	659	2.11	761	2.65	873	3.31	979	4.02	1154	5.41
5500	2414	368	1.10	450	1.48	552	1.91	664	2.46	760	3.02	853	3.64	955	4.37	1143	5.93
6000	2634	395	1.39	477	1.85	560	2.27	667	2.84	763	3.45	850	4.08	936	4.76	1120	6.39
6500	2854	423	1.74	504	2.28	574	2.69	673	3.27	767	3.93	852	4.59	931	5.28	1097	6.87
7000	3073	452	2.14	530	2.75	597	3.22	679	3.77	771	4.45	856	5.17	932	5.88	1078	7.41
7500	3293	480	2.60	555	3.27	622	3.83	690	4.34	777	5.04	859	5.78	936	6.56	1075	8.12
8000	3512	509	3.13	580	3.84	648	4.51	705	5.01	783	5.69	864	6.46	940	7.28	1076	8.92
8500	3732	538	3.72	605	4.47	675	5.26	728	5.80	792	6.43	870	7.22	944	8.05	1080	9.80
9000	3951	567	4.39	630	5.17	702	6.10	753	6.68	806	7.27	876	8.05	949	8.91	--	--

Model G18, 818 & 918

STANDARD SHAFTS SHOWN
LARGER SIZES AVAILABLE - 900's

G18
818
918

SHAFT DIAMETER
1"
1"
1-3/16"

MAXIMUM BHP
3
5
10

CFM	OUTLET VELOCITY FPM	1/8" SP		1/2" SP		1" SP		1-1/2" SP		2" SP		2-1/2" SP		3" SP		4" SP	
		RPM	BHP	RPM	BHP	RPM	BHP	RPM	BHP	RPM	BHP	RPM	BHP	RPM	BHP	RPM	BHP
4000	1395	246	0.30	395	0.58	568	1.05	731	1.79	855	2.51	956	3.21	1045	3.92	1199	5.37
4500	1569	263	0.40	402	0.72	556	1.16	713	1.88	848	2.72	956	3.52	1048	4.31	1206	5.91
5000	1743	281	0.52	411	0.88	554	1.34	691	1.95	832	2.85	949	3.79	1046	4.68	1210	6.43
5500	1918	299	0.66	423	1.08	557	1.57	681	2.13	810	2.95	933	3.96	1039	4.99	1210	6.94
6000	2092	319	0.83	435	1.29	563	1.82	679	2.40	790	3.07	913	4.08	1023	5.19	1206	7.42
6500	2266	339	1.03	448	1.52	571	2.12	680	2.71	785	3.38	890	4.20	1003	5.35	1196	7.77
7000	2441	360	1.25	462	1.79	581	2.45	685	3.07	784	3.75	880	4.51	980	5.48	1179	8.03
7500	2615	380	1.51	476	2.09	592	2.82	691	3.48	786	4.17	877	4.93	966	5.78	1159	8.23
8000	2790	401	1.81	492	2.42	604	3.23	700	3.93	790	4.65	877	5.41	962	6.25	1136	8.41
8500	2964	423	2.14	509	2.79	616	3.66	710	4.43	796	5.17	879	5.96	960	6.80	1118	8.71
9000	3138	444	2.52	526	3.21	628	4.12	721	4.97	804	5.75	884	6.56	961	7.41	1112	9.31
9500	3313	466	2.93	543	3.66	642	4.63	733	5.56	813	6.39	890	7.23	965	8.10	1109	9.99
10000	3487	488	3.39	562	4.16	656	5.18	745	6.18	823	7.07	898	7.95	970	8.84	--	--
10500	3661	510	3.90	580	4.70	671	5.77	757	6.84	835	7.82	907	8.73	976	9.66	--	--
11000	3836	532	4.46	599	5.30	686	6.42	769	7.54	847	8.61	917	9.57	--	--	--	--
11500	4010	554	5.06	619	5.94	702	7.12	782	8.29	859	9.44	--	--	--	--	--	--
12000	4185	577	5.73	638	6.65	719	7.87	796	9.09	--	--	--	--	--	--	--	--

Model 920-18

STANDARD SHAFTS SHOWN
LARGER SIZES AVAILABLE - 900's

SHAFT DIAMETER
1-3/16"
1-7/16"

MAXIMUM BHP
10
15

CFM	OUTLET VELOCITY FPM	1/8" SP		1/2" SP		1" SP		1-1/2" SP		2" SP		2-1/2" SP		3" SP		4" SP	
		RPM	BHP	RPM	BHP	RPM	BHP	RPM	BHP	RPM	BHP	RPM	BHP	RPM	BHP	RPM	BHP
5500	1406	274	0.58	386	0.96	513	1.55	624	2.24	726	2.97	818	3.68	900	4.38	1044	5.75
6000	1534	290	0.72	396	1.13	519	1.75	623	2.47	723	3.25	813	4.05	896	4.82	1041	6.33
6500	1662	308	0.89	408	1.34	525	1.98	627	2.72	720	3.54	809	4.39	892	5.26	1038	6.91
7000	1790	325	1.08	421	1.57	533	2.24	632	3.00	720	3.85	806	4.75	888	5.67	1034	7.50
7500	1918	344	1.30	435	1.84	541	2.53	638	3.31	724	4.19	805	5.12	884	6.10	1030	8.09
8000	2045	362	1.56	451	2.14	551	2.86	644	3.66	728	4.56	806	5.52	882	6.54	1026	8.64
8500	2173	381	1.84	467	2.47	561	3.22	651	4.05	734	4.96	810	5.95	882	7.00	1022	9.20
9000	2301	400	2.16	483	2.83	572	3.62	660	4.48	741	5.41	815	6.42	885	7.50	1019	9.78
9500	2429	419	2.52	500	3.24	585	4.07	669	4.95	748	5.90	821	6.93	889	8.03	1018	10.40
10000	2557	439	2.91	516	3.67	598	4.55	679	5.46	755	6.44	827	7.49	894	8.61	1019	11.00
10500	2685	458	3.34	532	4.13	612	5.08	689	6.02	764	7.02	834	8.09	901	9.23	1023	11.70
11000	2813	478	3.82	548	4.64	628	5.66	701	6.63	773	7.65	842	8.75	907	9.90	1027	12.40
11500	2941	498	4.34	565	5.19	644	6.28	713	7.28	783	8.34	850	9.46	914	10.60	1032	13.20
12000	3068	518	4.91	581	5.79	660	6.95	726	7.99	793	9.08	859	10.20	921	11.40	1038	14.00
12500	3196	538	5.52	599	6.43	676	7.67	740	8.75	804	9.87	868	11.00	929	12.30	1045	14.90
13000	3324	558	6.19	616	7.12	692	8.44	754	9.56	816	10.70	878	11.90	938	13.20	--	--
13500	3452	578	6.91	633	7.86	709	9.26	770	10.40	829	11.60	889	12.90	947	14.10	--	--
14000	3580	598	7.68	651	8.66	725	10.10	786	11.40	842	12.60	900	13.80	--	--	--	--
14500	3708	618	8.51	669	9.52	741	11.00	802	12.40	856	13.60	912	14.90	--	--	--	--
15000	3836	638	9.40	688	10.40	757	12.00	818	13.40	871	14.70	--	--	--	--	--	--

Model 920

SHAFT DIAMETER

MAXIMUM BHP

1-3/16"
1-7/16"

10
15

STANDARD SHAFTS SHOWN

LARGER SIZES AVAILABLE - 900's

CFM	OUTLET VELOCITY	1/8" SP		1/2" SP		1" SP		1-1/2" SP		2" SP		2-1/2" SP		3" SP		4" SP	
	FPM	RPM	BHP	RPM	BHP	RPM	BHP	RPM	BHP	RPM	BHP	RPM	BHP	RPM	BHP	RPM	BHP
5000	1175	236	0.37	364	0.72	511	1.36	634	2.08	735	2.83	822	3.62	899	4.44	1028	6.13
6000	1410	265	0.58	378	0.98	510	1.65	627	2.45	731	3.31	821	4.20	901	5.12	1040	7.04
7000	1645	296	0.86	397	1.32	514	2.01	624	2.87	724	3.81	815	4.80	897	5.83	1040	7.95
8000	1880	328	1.23	420	1.76	526	2.49	626	3.36	721	4.37	808	5.44	891	6.56	1036	8.89
9000	2115	361	1.70	445	2.30	544	3.08	634	3.97	722	5.01	806	6.14	884	7.34	1030	9.87
10000	2350	394	2.28	472	2.96	564	3.81	648	4.73	728	5.77	807	6.94	883	8.20	1023	10.90
11000	2585	428	2.99	501	3.75	587	4.67	666	5.64	740	6.70	812	7.88	884	9.17	1019	12.00
12000	2820	463	3.83	530	4.65	611	5.68	686	6.70	756	7.81	823	9.00	890	10.30	1020	13.20
13000	3056	498	4.82	561	5.70	637	6.85	708	7.93	774	9.09	838	10.30	900	11.60	1022	14.60
14000	3291	533	5.98	592	6.91	664	8.18	732	9.34	795	10.50	856	11.80	914	13.20	1028	16.10
15000	3526	568	7.30	624	8.30	693	9.69	757	10.90	817	12.20	875	13.50	931	14.90	1039	17.90
16000	3761	604	8.82	656	9.87	722	11.40	783	12.70	841	14.10	896	15.40	950	16.90	1053	19.90
17000	3996	639	10.50	689	11.60	751	13.20	810	14.70	866	16.10	919	17.50	971	19.00	1069	22.20
18000	4231	675	12.50	722	13.60	781	15.30	838	16.90	891	18.40	943	19.90	993	21.40	1088	24.70

Model 922

SHAFT DIAMETER

MAXIMUM BHP

1-3/16"
1-7/16"

10
15

STANDARD SHAFTS SHOWN

LARGER SIZES AVAILABLE - 900's

CFM	OUTLET VELOCITY	1/8" SP		1/2" SP		1" SP		1-1/2" SP		2" SP		2-1/2" SP		3" SP		4" SP	
	FPM	RPM	BHP	RPM	BHP	RPM	BHP	RPM	BHP	RPM	BHP	RPM	BHP	RPM	BHP	RPM	BHP
7000	1357	237	0.61	348	1.09	466	1.81	570	2.68	665	3.68	751	4.73	827	5.82	961	8.05
8000	1551	260	0.86	361	1.41	472	2.18	569	3.06	659	4.09	742	5.22	820	6.42	956	8.89
9000	1745	284	1.18	377	1.78	481	2.62	573	3.54	657	4.59	736	5.75	811	7.01	949	9.69
10000	1939	309	1.56	394	2.23	493	3.15	580	4.13	660	5.19	735	6.37	806	7.66	940	10.50
11000	2133	334	2.03	412	2.76	507	3.77	589	4.80	665	5.91	737	7.10	805	8.41	933	11.30
12000	2327	360	2.59	432	3.38	521	4.47	601	5.58	674	6.74	742	7.97	807	9.29	930	12.20
13000	2520	386	3.24	453	4.09	537	5.27	614	6.47	684	7.69	749	8.97	812	10.30	930	13.30
14000	2714	412	4.00	475	4.91	554	6.17	628	7.46	696	8.76	759	10.10	819	11.50	933	14.50
15000	2908	439	4.87	498	5.85	573	7.19	643	8.56	709	9.95	770	11.40	828	12.80	938	15.90
16000	3102	466	5.86	521	6.90	592	8.33	659	9.78	723	11.30	782	12.70	838	14.30	944	17.40
17000	3296	492	6.98	545	8.09	612	9.59	677	11.10	738	12.70	796	14.30	850	15.90	953	19.10
18000	3490	519	8.24	569	9.41	633	11.00	695	12.60	754	14.30	810	15.90	863	17.60	963	21.00
19000	3684	546	9.65	594	10.90	655	12.60	714	14.30	770	16.00	825	17.70	877	19.50	974	23.00
20000	3878	574	11.20	619	12.50	677	14.30	733	16.00	788	17.80	841	19.70	892	21.50	986	25.20

Model 925

SHAFT DIAMETER

MAXIMUM BHP

1-3/16"
1-7/16"

10
15

STANDARD SHAFTS SHOWN

LARGER SIZES AVAILABLE - 900's

CFM	OUTLET VELOCITY	1/8" SP		1/2" SP		1" SP		1-1/2" SP		2" SP		2-1/2" SP		3" SP		4" SP	
	FPM	RPM	BHP	RPM	BHP	RPM	BHP	RPM	BHP	RPM	BHP	RPM	BHP	RPM	BHP	RPM	BHP
10000	1474	216	0.95	314	1.64	418	2.68	509	3.87	592	5.19	666	6.57	733	7.98	850	10.80
11000	1622	231	1.21	322	1.95	423	3.08	509	4.29	589	5.67	663	7.15	730	8.67	848	11.80
12000	1769	246	1.51	332	2.31	429	3.51	511	4.80	587	6.19	660	7.74	726	9.36	844	12.70
13000	1916	262	1.86	342	2.73	435	4.00	516	5.36	588	6.80	657	8.38	723	10.10	842	13.60
14000	2064	278	2.27	353	3.22	443	4.54	521	5.99	591	7.49	656	9.08	720	10.80	838	14.60
15000	2211	295	2.73	365	3.77	451	5.15	527	6.67	596	8.25	659	9.90	719	11.60	835	15.50
16000	2359	311	3.26	378	4.39	460	5.82	534	7.41	601	9.07	662	10.80	721	12.60	832	16.50
17000	2506	328	3.85	391	5.07	469	6.56	541	8.22	607	9.96	667	11.80	724	13.60	830	17.60
18000	2654	345	4.51	405	5.83	480	7.38	549	9.11	613	10.90	673	12.80	728	14.70	831	18.70
19000	2801	362	5.25	419	6.66	491	8.30	558	10.10	620	12.00	678	13.90	733	15.90	834	20.10
20000	2949	379	6.07	433	7.57	502	9.32	567	11.10	628	13.10	685	15.10	738	17.20	837	21.50
21000	3096	396	6.97	448	8.56	514	10.40	577	12.30	636	14.30	691	16.40	744	18.60	841	23.00
22000	3244	413	7.96	463	9.64	527	11.60	587	13.50	645	15.60	699	17.80	751	20.00	846	24.60
23000	3391	430	9.04	478	10.80	540	12.90	598	14.90	654	17.00	707	19.20	757	21.50	852	26.30
24000	3538	448	10.20	493	12.10	553	14.30	610	16.30	664	18.50	715	20.80	765	23.20	858	28.10
25000	3686	465	11.50	509	13.40	566	15.80	621	17.90	674	20.10	724	22.50	773	24.90	864	30.00

Model 927

SHAFT DIAMETER

MAXIMUM BHP

1-11/16"
2-7/16"

25
50

STANDARD SHAFTS SHOWN
OTHER SIZES AVAILABLE - 900's

CFM	OUTLET VELOCITY FPM	1/8" SP		1/2" SP		1" SP		1-1/2" SP		2" SP		2-1/2" SP		3" SP		4" SP	
		RPM	BHP	RPM	BHP	RPM	BHP	RPM	BHP	RPM	BHP	RPM	BHP	RPM	BHP	RPM	BHP
14000	1718	199	1.51	277	2.46	359	3.81	428	5.26	510	7.34	585	9.64	649	11.90	758	16.50
15000	1841	210	1.81	283	2.82	364	4.27	430	5.73	501	7.63	578	10.10	644	12.50	755	17.40
16000	1964	220	2.15	290	3.22	370	4.74	434	6.29	495	8.02	567	10.40	637	13.00	751	18.20
17000	2086	231	2.53	298	3.67	375	5.26	439	6.91	496	8.61	559	10.80	627	13.40	745	19.00
18000	2209	241	2.96	306	4.16	381	5.83	445	7.59	499	9.32	553	11.30	617	13.80	739	19.70
19000	2332	252	3.43	314	4.70	387	6.44	450	8.28	504	10.10	554	12.00	610	14.40	731	20.40
20000	2455	264	3.95	323	5.29	393	7.10	455	9.02	509	11.00	558	12.90	606	15.10	720	20.90
21000	2577	275	4.53	332	5.94	399	7.82	460	9.81	515	11.90	562	13.90	608	16.00	711	21.40
22000	2700	286	5.16	341	6.64	406	8.60	466	10.70	520	12.80	567	14.90	611	17.10	704	22.10
23000	2823	297	5.86	351	7.39	413	9.43	472	11.60	525	13.80	573	16.10	616	18.20	700	23.10
24000	2946	309	6.61	360	8.21	421	10.30	478	12.50	530	14.80	578	17.20	621	19.50	701	24.30
25000	3068	320	7.43	370	9.08	429	11.30	485	13.60	536	16.00	583	18.40	626	20.80	704	25.70
26000	3191	332	8.31	379	10.00	437	12.30	491	14.70	542	17.10	588	19.60	632	22.20	708	27.20
27000	3314	343	9.26	389	11.00	446	13.40	498	15.90	548	18.40	594	21.00	637	23.60	713	28.80
28000	3437	355	10.30	399	12.10	454	14.60	505	17.10	554	19.70	600	22.40	642	25.10	718	30.50
29000	3559	367	11.40	409	13.30	463	15.90	512	18.40	561	21.10	606	23.80	647	26.60	724	32.30
30000	3682	378	12.60	420	14.50	473	17.20	520	19.80	567	22.60	612	25.40	653	28.30	729	34.10
31000	3805	390	13.80	430	15.80	482	18.60	528	21.30	574	24.10	618	27.00	659	30.00	734	36.00
32000	3928	402	15.20	441	17.20	491	20.10	537	22.90	581	25.80	624	28.70	665	31.80	740	37.90
33000	4050	414	16.60	451	18.70	501	21.70	545	24.60	588	27.50	630	30.50	671	33.60	745	40.00
34000	4173	426	18.10	462	20.20	510	23.30	554	26.30	596	29.30	637	32.40	677	35.60	751	42.10

Model 930

SHAFT DIAMETER

MAXIMUM BHP

1-11/16"
2-11/16"

30
60

STANDARD SHAFTS SHOWN
OTHER SIZES AVAILABLE - 900's

CFM	OUTLET VELOCITY FPM	1/8" SP		1/2" SP		1" SP		1-1/2" SP		2" SP		2-1/2" SP		3" SP		4" SP	
		RPM	BHP	RPM	BHP	RPM	BHP	RPM	BHP	RPM	BHP	RPM	BHP	RPM	BHP	RPM	BHP
20000	2132	202	2.89	265	4.27	333	6.15	390	8.10	446	10.20	503	12.70	558	15.50	655	21.20
21000	2239	210	3.30	271	4.74	338	6.72	393	8.73	447	10.90	501	13.30	554	16.10	652	22.10
22000	2345	218	3.75	277	5.25	343	7.32	396	9.41	448	11.60	499	14.00	551	16.80	648	22.90
23000	2452	226	4.23	283	5.80	348	7.97	401	10.10	451	12.40	500	14.80	549	17.50	644	23.70
24000	2558	234	4.76	289	6.40	353	8.66	405	10.90	453	13.20	501	15.70	547	18.30	641	24.60
25000	2665	243	5.34	296	7.04	358	9.38	410	11.70	456	14.10	502	16.60	547	19.30	638	25.40
26000	2772	251	5.96	303	7.73	363	10.10	415	12.60	460	15.10	504	17.60	548	20.30	635	26.40
27000	2878	260	6.63	309	8.46	368	11.00	420	13.50	465	16.00	507	18.70	549	21.40	633	27.40
28000	2985	268	7.35	316	9.24	374	11.80	426	14.50	469	17.10	510	19.80	551	22.60	632	28.50
29000	3092	276	8.12	323	10.10	379	12.70	431	15.50	474	18.20	514	21.00	554	23.80	632	29.80
30000	3198	285	8.95	330	11.00	385	13.70	436	16.60	479	19.40	519	22.20	557	25.10	633	31.20
31000	3305	294	9.83	337	11.90	391	14.70	441	17.70	485	20.60	523	23.50	560	26.50	634	32.70
32000	3411	302	10.80	344	12.90	397	15.80	446	18.80	490	21.90	528	24.80	565	27.90	636	34.20
33000	3518	311	11.80	352	13.90	403	17.00	451	20.00	495	23.20	533	26.30	569	29.40	639	35.80
34000	3625	319	12.80	359	15.10	410	18.20	456	21.30	500	24.60	539	27.70	574	30.90	641	37.50
35000	3731	328	14.00	366	16.20	416	19.40	462	22.70	505	26.00	544	29.30	579	32.60	644	39.30
36000	3838	337	15.10	374	17.50	423	20.80	467	24.10	510	27.50	549	30.90	584	34.30	648	41.10
37000	3945	345	16.40	382	18.80	430	22.20	473	25.60	515	29.10	554	32.60	589	36.00	652	43.00
38000	4051	354	17.70	389	20.20	436	23.70	479	27.10	520	30.70	559	34.30	594	37.90	657	45.00
39000	4158	363	19.10	397	21.60	443	25.20	485	28.70	525	32.40	564	36.10	599	39.80	661	47.10
40000	4264	372	20.60	405	23.10	450	26.80	491	30.40	531	34.10	569	37.90	605	41.80	666	49.20
41000	4371	380	22.10	413	24.70	457	28.50	498	32.20	536	36.00	574	39.90	610	43.80	671	51.40
42000	4478	389	23.70	421	26.40	464	30.20	504	34.10	542	37.90	579	41.90	615	45.90	676	53.70
43000	4584	398	25.40	429	28.10	471	32.10	511	36.00	548	39.90	584	43.90	619	48.10	681	56.10

Model 933

SHAFT DIAMETER

MAXIMUM BHP

2-3/16"
2-11/16"

40
100

STANDARD SHAFTS SHOWN
OTHER SIZES AVAILABLE - 900's

CFM	OUTLET VELOCITY	1/8" SP		1/2" SP		1" SP		1-1/2" SP		2" SP		2-1/2" SP		3" SP		4" SP	
	FPM	RPM	BHP	RPM	BHP	RPM	BHP	RPM	BHP	RPM	BHP	RPM	BHP	RPM	BHP	RPM	BHP
24000	2024	185	3.81	241	5.56	299	7.80	354	10.30	400	12.70	444	15.20	496	18.70	611	28.10
26000	2193	197	4.75	251	6.66	306	9.04	358	11.70	405	14.30	446	16.90	487	19.80	589	28.30
28000	2362	210	5.83	261	7.91	314	10.50	363	13.20	410	16.10	450	18.90	488	21.70	571	28.80
30000	2530	223	7.08	270	9.27	323	12.00	369	14.90	413	18.00	455	21.10	491	24.00	562	30.40
32000	2699	236	8.50	280	10.80	332	13.80	376	16.80	418	20.00	459	23.30	496	26.60	563	33.00
34000	2868	249	10.10	290	12.50	341	15.80	384	18.90	423	22.10	463	25.70	501	29.30	566	36.00
36000	3037	262	11.90	300	14.30	351	18.00	392	21.20	430	24.60	468	28.20	505	32.00	570	39.20
38000	3205	275	13.90	311	16.40	361	20.30	401	23.80	438	27.30	473	30.90	509	34.80	576	42.80
40000	3374	288	16.20	323	18.80	371	22.90	410	26.50	446	30.20	480	34.00	514	37.90	580	46.40
42000	3543	301	18.60	334	21.30	380	25.60	420	29.60	455	33.30	488	37.20	520	41.30	584	50.00
44000	3712	314	21.30	346	24.10	390	28.50	430	32.80	464	36.80	496	40.80	527	45.00	588	53.90
46000	3880	328	24.30	358	27.20	400	31.70	439	36.40	473	40.50	504	44.70	534	48.90	593	58.00
48000	4049	341	27.50	371	30.50	410	35.10	449	40.10	482	44.50	513	48.80	542	53.20	599	62.40
50000	4218	355	31.00	383	34.10	420	38.80	459	44.10	492	48.80	522	53.20	551	57.80	606	67.20
52000	4386	368	34.80	395	38.00	430	42.80	468	48.20	502	53.30	532	58.00	559	62.60	613	72.30
54000	4555	381	38.90	408	42.20	442	47.10	478	52.70	512	58.20	541	63.10	568	67.90	621	77.80
56000	4724	395	43.30	421	46.70	453	51.70	488	57.40	522	63.30	551	68.40	578	73.40	629	83.60

Model 936

SHAFT DIAMETER

MAXIMUM RPM

2-3/16"
2-11/16"

40
100

STANDARD SHAFTS SHOWN
OTHER SIZES AVAILABLE - 900's

CFM	OUTLET VELOCITY	1/8" SP		1/2" SP		1" SP		1-1/2" SP		2" SP		2-1/2" SP		3" SP		4" SP	
	FPM	RPM	BHP	RPM	BHP	RPM	BHP	RPM	BHP	RPM	BHP	RPM	BHP	RPM	BHP	RPM	BHP
30000	2353	198	6.04	241	8	293	10.7	340	13.80	383	16.90	422	19.90	462	23.20	563	33.20
32000	2510	209	7.25	249	9.32	300	12.20	345	15.30	387	18.70	425	22.00	462	25.20	547	33.80
34000	2667	221	8.62	257	10.80	307	13.80	350	17.00	391	20.50	429	24.10	464	27.50	536	35.10
36000	2824	233	10.20	266	12.30	315	15.60	357	18.90	396	22.60	433	26.30	468	30.10	532	37.40
38000	2980	245	11.90	275	14.10	323	17.60	364	21.00	401	24.70	437	28.70	471	32.70	534	40.40
40000	3137	257	13.80	285	16.00	330	19.80	371	23.30	407	27.10	442	31.20	475	35.40	537	43.60
42000	3294	269	15.90	295	18.20	339	22.10	378	25.80	413	29.70	447	33.90	480	38.30	541	47.10
44000	3451	281	18.20	306	20.50	347	24.70	386	28.50	420	32.50	453	36.80	485	41.30	545	50.60
46000	3608	294	20.70	316	23.10	355	27.40	393	31.50	427	35.60	459	40.00	490	44.50	548	54.20
48000	3765	306	23.50	327	26.00	364	30.30	401	34.60	435	38.90	466	43.30	496	48.00	553	57.90
50000	3922	318	26.50	339	29.00	373	33.40	409	38.00	442	42.40	473	47.00	502	51.80	558	61.90
52000	4079	330	29.70	350	32.40	382	36.70	417	41.70	450	46.20	480	50.90	508	55.80	563	66.10
54000	4236	342	33.20	361	35.90	391	40.30	425	45.50	457	50.30	487	55.00	515	60.00	568	70.60
56000	4392	355	37.00	373	39.80	401	44.20	434	49.60	465	54.60	495	59.40	522	64.60	574	75.30
58000	4549	367	41.00	384	43.90	411	48.30	442	53.90	473	59.20	502	64.20	530	69.40	580	80.40
60000	4706	379	45.40	396	48.30	421	52.80	451	58.40	482	64.00	510	69.30	537	74.50	587	85.70
62000	4863	392	50.00	408	53.00	431	57.50	460	63.20	490	69.20	518	74.60	545	80.00	594	91.40