

GENERAL DIMENSIONAL DATA FOR ARRANGEMENT NO. 3 CLASS I AND II, SWSI

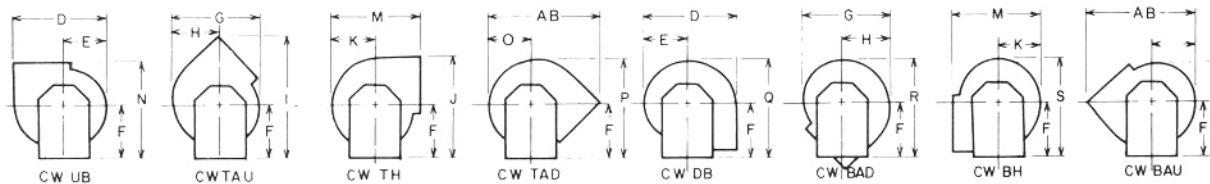
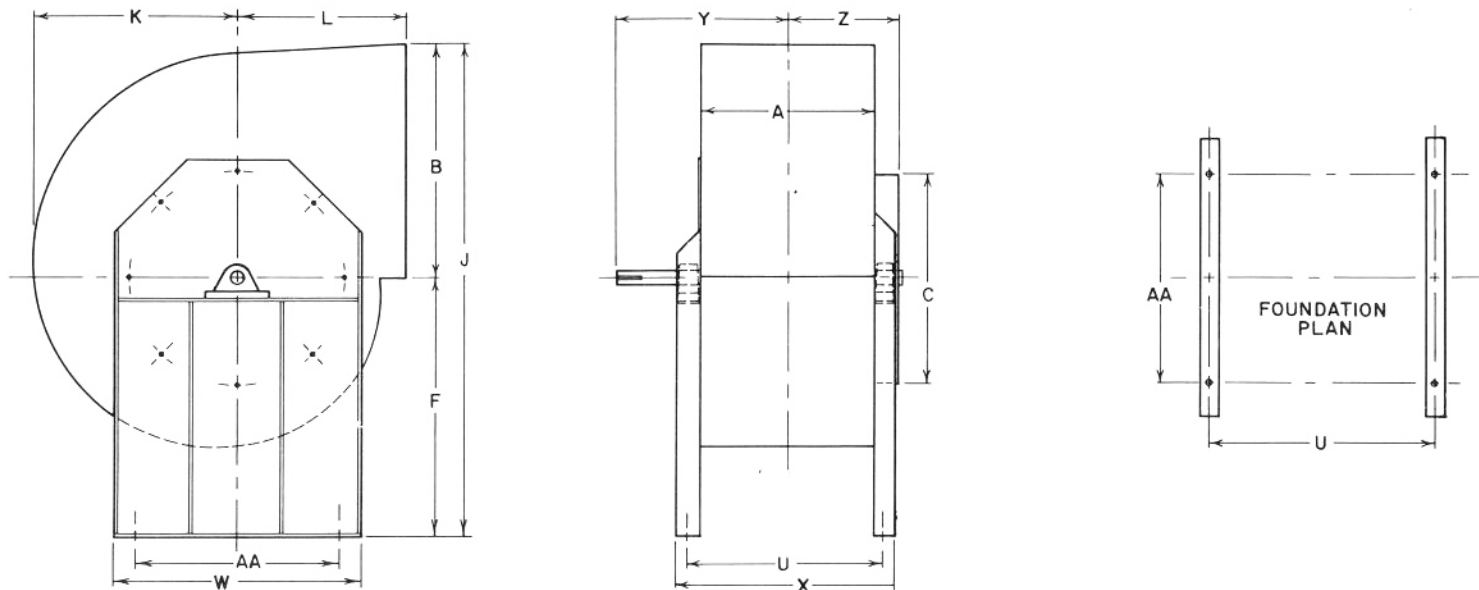

General Air Products & Systems
 A Division of the General Marketing Group
 123 Waterloo St.
 Kitchener, Ontario, Canada
 N2H 3V5

UNIT SIZE	C.F.M.	S.P.	B.H.P.	RPM	D.V.	MOTOR H.P.	CURRENT	MOTOR V.	MOTOR ϕ	TAG UNIT	ACCESSORIES	JOB
												LOCATION
												CONTRACTOR
												ENGINEER/ARCHITECT

SIZE	A	B	C	D	E	F	G	H	I	J	K	L	M	N	O	P	Q	R	S	T	U	W	X	Y	Z	AA	AB	SHAFT DIA.	
																										CLASS I	CLASS II		
100	9	12 1/8	11	20 3/16	8	14 3/4	17 7/8	8 3/8	29 11/16	26 7/8	9 3/4	9	18 3/4	23 3/4	9	25 3/8	24 1/2	23 3/4	22 13/16	22	10 1/4	15	11 1/4	10 3/4	6	12	23 15/16	1	1
122	9 3/4	13 1/8	12 7/8	22 1/4	9 3/8	14 1/2	20 5/8	11 7/8	30 5/8	27 5/8	10 7/8	9 1/2	20 3/8	24	10 3/8	26 1/2	25 5/8	24 3/4	23 7/8	23 1/4	11 1/4	16 1/4	12 1/4	10 3/4	6 7/8	13 1/4	26 1/4	1 3/16	1 3/16
135	10 3/4	14 1/2	14 1/8	25	10 1/2	16 1/2	22 5/8	13	33 7/8	31	12 1/4	10 3/8	22 5/8	26 7/8	11 3/8	29 5/8	28 3/4	27 7/8	27	26 1/4	12 1/4	17 5/8	13 1/4	11 1/4	7 3/8	14 1/4	28 3/4	1 3/16	1 3/16
150	12	16 1/8	15 3/4	27 1/2	11 3/8	18 1/2	25 1/4	14 1/2	37 7/8	34 5/8	13 1/2	11 5/8	25 1/8	30 1/8	12 5/8	33 1/8	32 1/8	31 1/8	30 1/8	29 1/4	13 1/2	18 3/4	14 1/2	11 7/8	8 1/2	15 1/2	32 1/8	1 3/16	1 3/16
165	13 1/8	17 5/8	17 3/8	30 1/4	12 5/8	20 1/2	27 3/4	16	41 3/4	38 1/8	14 7/8	12 3/4	27 5/8	33 1/4	13 7/8	36 5/8	35 1/2	34 3/8	33 1/8	32 3/8	14 3/4	20 1/4	15 3/4	12 1/2	8 3/4	17 1/4	35 1/4	1 3/16	1 3/16
180	14 3/8	19 3/8	19	33 1/8	14	22 1/2	30 1/2	17 1/2	45 7/8	41 7/8	16 3/8	14	30 3/8	36 1/2	15 1/4	40 1/8	38 7/8	37 3/4	36 1/2	35 1/2	16 1/2	22 3/8	17 1/2	13 3/4	9 7/8	19 3/8	38 1/4	1 3/16	1 3/16
200	15 3/8	21 3/8	20 7/8	36 5/8	15 1/4	24 3/4	33 5/8	19 5/8	50 1/2	46 1/8	18 1/8	15 1/2	33 1/4	40 1/4	16 7/8	44 1/4	42 7/8	41 5/8	40	39 1/8	17 3/4	25	19 3/4	15 1/4	10 3/8	21 1/2	42 3/4	1 3/16	1 7/16
220	17	23 5/8	23 1/16	40 1/2	16 7/8	28 1/4	37 1/8	21 3/8	56 3/4	51 7/8	20	17 1/8	37 1/8	45 3/8	18 5/8	49 7/8	48 1/4	46 7/8	45 1/8	44 1/8	19 1/2	27 3/8	21 1/2	17	11 3/4	23 1/2	47 1/4	1 7/16	1 7/16
240	19 1/4	25 5/8	25 5/8	44 5/8	18 1/2	28 1/4	41	23 1/2	59 5/8	53 7/8	22	18 7/8	40 7/8	47 1/8	20 1/2	52	50 1/4	48 3/4	46 3/4	45 3/4	21 1/4	29 3/4	23 1/4	18 1/4	12 5/8	25 1/2	52 1/8	1 7/16	1 11/16
270	21 5/8	28 7/8	28 3/4	49 3/8	20 1/2	32	45 3/8	26 1/8	66 7/8	60 7/8	24 3/8	20 7/8	45 1/4	52 7/8	22 3/4	58 3/8	56 3/8	54 3/4	52.50	51 3/8	23 3/8	32 1/8	25 3/8	19 1/4	13 5/8	25 3/4	57 3/4	1 11/16	1 11/16

We reserve the right to make dimensional changes without notice. Certified dimensions furnished upon request.

GENERAL DIMENSIONAL DATA FOR ARRANGEMENT NO. 3 CLASS I AND II, SWSI

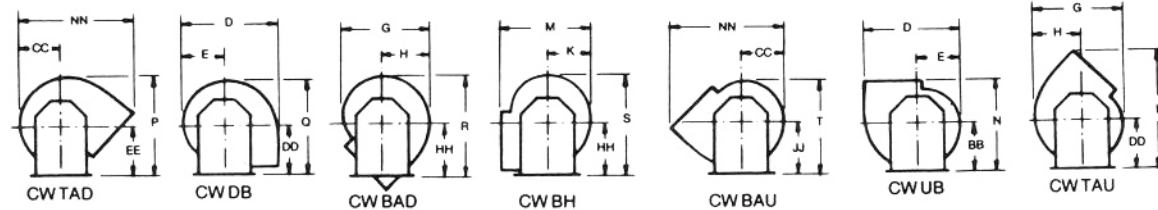
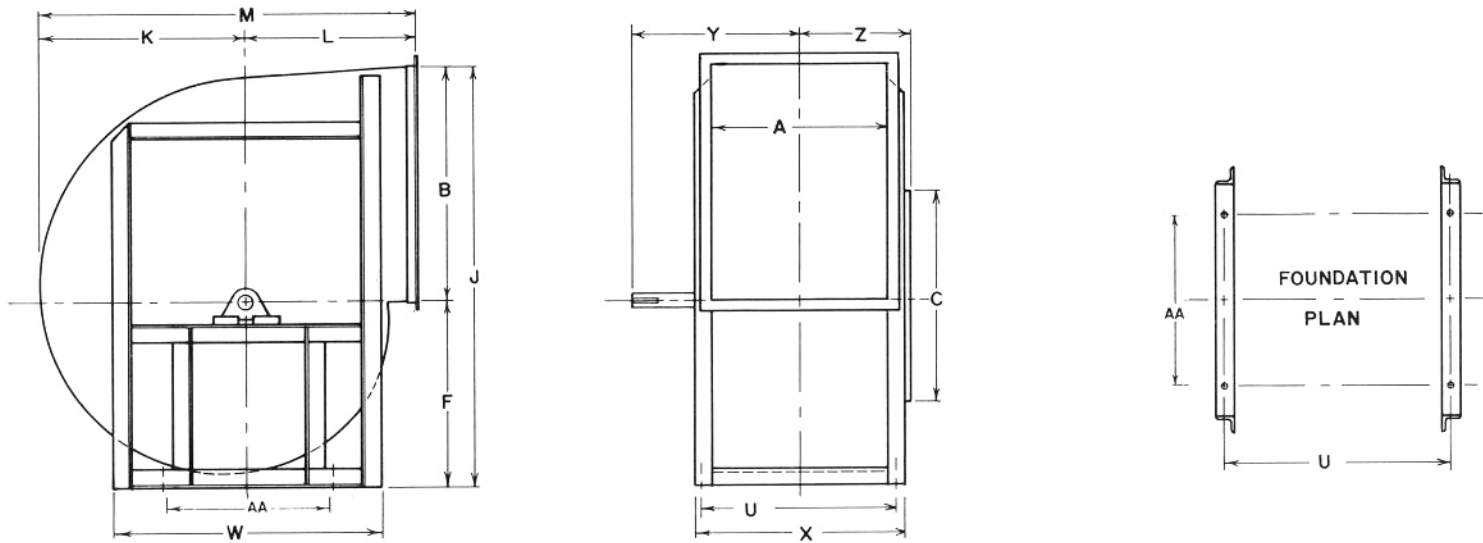

**General Air
Products & Systems**
A Division of the General Marketing Group

123 Waterloo St.
Kitchener, Ontario, Canada
N2H 3V5

UNIT SIZE	C.F.M.	S.P.	B.H.P.	RPM	O.V.	MOTOR H.P.	CURRENT	MOTOR V.	MOTOR Φ	TAG UNIT

SIZE	A	B	C	D	E	F	G	H	I	J	K	L	M	N	O	P	Q	R	S	T	U	W	X	Y	Z	BB	DD	EE	HH	JJ	NN	SHAFT DIA.	
																	CLASS I	CLASS II															
300	24	32	32	55 3/8	23 1/4	26 1/2	50 3/8	29	67 1/8	58 1/2	27 1/8	23 1/8	50 1/4	53	25 1/4	53 1/2	54	59 7/8	60	50 3/4	26 1/4	35 1/2	28 3/4	21 1/8	14 5/8	29 7/8	23 7/8	26 1/8	34 5/8	29 3/4	62 3/8	1 15/16	1 15/16
330	26 1/2	35 1/4	35 1/4	60 7/8	25 1/2	27 1/2	55 1/2	31 7/8	70 1/8	63	29 7/8	25 1/2	55 3/8	56 7/8	27 3/4	59 3/4	57 5/8	65 5/8	63	55 3/4	28 1/2	44 3/4	31	22 1/4	16 5/8	31 3/8	26 1/4	27 3/4	37 7/8	32 1/2	70 1/2	1 15/16	2 3/16
360	29 1/4	39	39	67	28 1/8	29 1/2	61 1/8	35 1/8	76 3/8	68 7/8	32 7/8	28 1/8	61	62 1/2	30 5/8	65	62 7/8	72	68 3/4	61 3/8	31 1/4	48	33 3/4	23 5/8	17 7/8	34 3/8	29	30 1/2	41 3/8	35 3/4	78	2 3/16	2 7/16
400	32 1/4	43	43	73 5/8	30 7/8	33	67 1/4	38 5/8	84 5/8	76 3/8	36 1/8	30 7/8	67	68 1/2	33 5/8	72	68 1/8	79 3/8	75 1/4	68	34 1/8	52 1/2	37 1/8	24 7/8	19	37 5/8	31 3/4	32 1/2	45 3/4	39 3/4	86	2 3/16	2 7/16
440	35 5/8	47 1/2	47 1/2	82	34 3/8	35 1/2	74 3/4	43	92 7/8	83 1/2	40 1/4	34 3/8	74 5/8	76 1/8	37 3/8	78 7/8	75 3/4	88	83 3/4	74 3/4	37 5/8	56 1/2	40 5/8	27 1/4	20 3/4	41 3/4	35 1/4	36 1/4	50 5/8	43 3/4	95 1/8	2 7/16	2 11/16
490	39 1/4	52 5/16	52 1/4	90	37 7/8	39 3/8	82 3/8	47 3/8	102 1/4	102 1/4	44 1/4	37 7/8	82 1/8	83 5/8	41 1/4	86 3/4	83 1/4	96 3/8	91 5/8	82 1/4	41 1/8	61 1/2	44 1/8	29 5/8	22 1/2	45 3/4	38 3/4	38 7/8	55 1/8	48	104 3/4	2 11/16	2 15/16
540	43 1/2	58	57 15/16	99 3/8	41 3/4	43 1/2	90 3/4	52 1/8	113 1/8	102	48 7/8	41 3/4	90 5/8	92 1/8	45 3/8	96 1/8	92 3/8	107	101 1/4	90 3/4	46	67	50	33	24 1/2	50 3/8	42 5/8	42 1/4	61 5/8	52 1/4	116	2 15/16	3 7/16
600	48 1/8	64	64 1/16	110 5/8	46 3/8	48	100 3/4	58	125 3/8	112 5/8	54 1/4	46 3/8	100 5/8	102	50 1/2	106 1/2	102 1/4	117 3/4	112 1/4	100	50 5/8	73	54 5/8	34 5/8	26 7/8	55 5/8	47 1/4	45 1/8	67 1/4	57 3/4	128 1/4	2 15/16	3 7/16
660	52 15/16	70 7/16	70 1/2	121 5/8	51	52 1/2	110 7/8	63 3/4	137 5/8	123 5/8	59 5/8	51	110 5/8	112 3/8	55 1/2	116 7/8	112 1/8	131	123 1/2	109 1/2	55 1/4	80	61 1/4	39 1/2	29 1/8	61 3/8	51 7/8	49 1/2	75 5/8	63 1/8	141	3 7/16	3 15/16
730	58 1/2	77 15/16	77 15/16	136 1/8	58	59	122 5/8	70 1/2	151 1/4	135 3/4	66	56 3/8	122 3/8	124 1/8	61 3/8	128 1/8	123	144 1/2	137 5/8	131 1/4	61 3/4	88	66 3/4	45 5/8	31 7/8	67 3/4	57 1/4	54 1/4	83 1/8	69 3/4	156	3 7/16	3 15/16
805	64 9/16	86	86	149	61 1/4	63	131 1/8	74	173 1/4	149 3/4	69 1/2	64 1/8	133 5/8	136 1/8	65 3/8	133 1/2	133 5/8	154 3/8	150 1/4	133 5/8	68 7/8	95 1/2	73 5/8	47 1/2	37 7/8	72	67 1/2	59 1/2	89	76 1/2	171 1/2	3 15/16	4 7/16
890	71.38	95	95	164	67 1/2	69 1/4	144 1/2	81 1/2	189 1/4	165 1/4	76 5/8	70	146 5/8	148 1/4	72	147	146 5/8	169 7/8	165 1/4	147 7/8	75 3/8	106 1/2	80 1/8	50 3/4	42 1/8	78 1/4	70	65 1/2	97 3/4	85	188 3/8	3 15/16	4 15/16

We reserve the right to make dimensional changes without notice. Certified dimensions furnished upon request.