

SIS SERIES DIMENSIONS

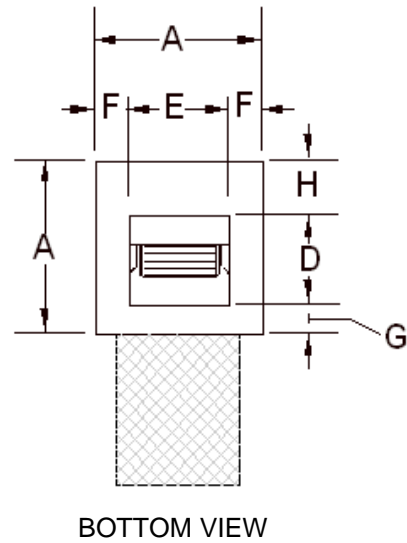
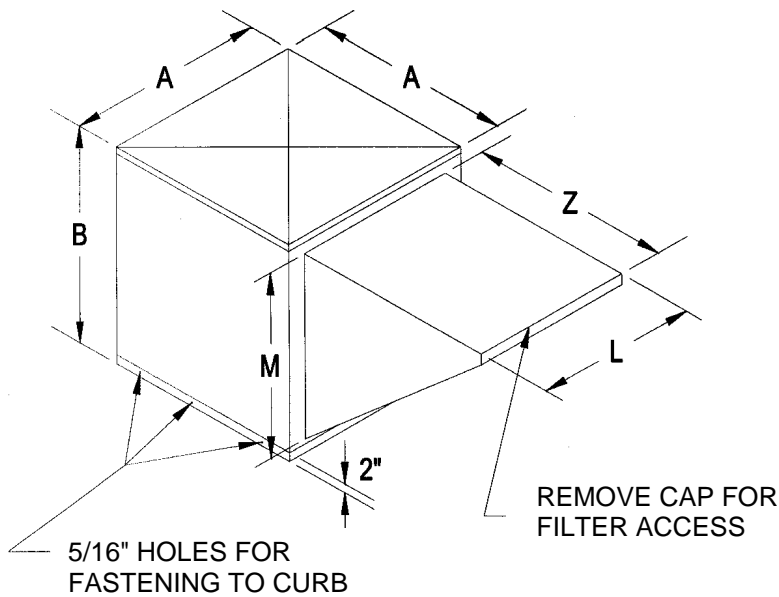

DIMENSIONS (inches)

NOTE: WT. SHOWN IS LESS MOTOR AND DRIVE

MODEL	A	B	D	E	F	G	H	L	M	Z	FILTER SIZE (QTY.)	* INSIDE CABINET	UNIT WT. (LBS.)
SIS-9	24-3/8	19-3/8	10-1/4	11-13/16	6-9/32	7-1/16	7-1/16	19-1/4	16-9/16	21-1/4	16 x 24 x 1 (1)	24x24	70
SIS-10	28-3/8	21-3/8	11-3/8	13-1/8	7-5/8	8-1/2	8-1/2	20-1/2	18-9/16	25-3/4	15 x 20 x 1 (2)	28x28	87
SIS-12	32-3/8	24-5/8	13-7/16	15-5/8	8-1/16	9-3/8	9-3/8	25-3/8	21-9/16	30-3/4	20 x 25 x 1 (1) & 16 x 25 x 1 (1)	32x32	117
SIS-15	36-3/8	28-3/8	15-7/8	18-5/8	8-1/2	7-3/4	12-5/16	31-3/16	25-13/16	33-1/2	20 x 28-1/2 x 1 (2)	36x36	175
SIS-18	36-3/8	42-1/2	18-7/8	21-7/8	7-1/4	6	11-1/2	35-5/8	32-11/16	40-1/4	20 x 25 x 1 (2) & 16 x 25 x 1 (2)	36x36	262
SIS-20	44-3/8	49	24-3/4	24-3/4	9-13/16	14-7/16	5-3/16	38-5/8	35-9/16	45-1/2 **	20 x 25 x 1 (6)	44x44	497

* CURB SIZE TO BE SMALLER THAN INSIDE CABINET SIZE TO ALLOW FOR FLASHING AND ROOFING

** INCLUDES FILTER SECTION

TYPICAL INSTALLATION

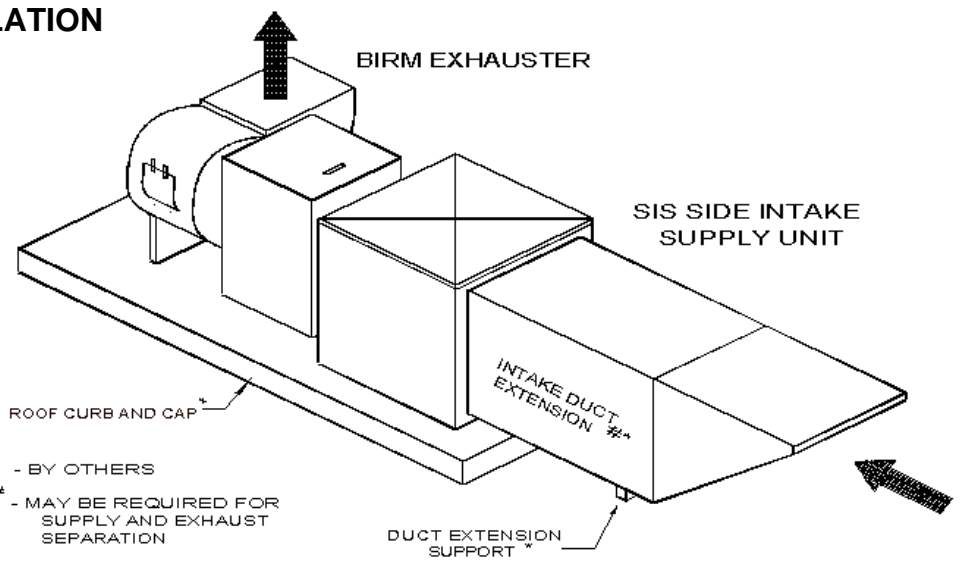

* - BY OTHERS
 # - MAY BE REQUIRED FOR SUPPLY AND EXHAUST SEPARATION

SIS SERIES BLOWERS

SUBMITTAL DRAWING

- BALL BEARINGS
- PERMANENT WASHABLE FILTERS
- WEATHER RESISTANT ENAMEL PAINT FINISH ON GALVANIZED STEEL
- QUIET FORWARD CURVED BLOWER
- LATCHED TOP COVER

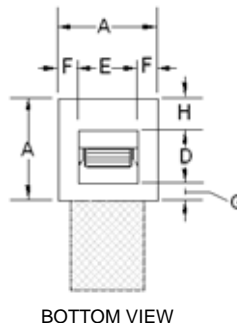
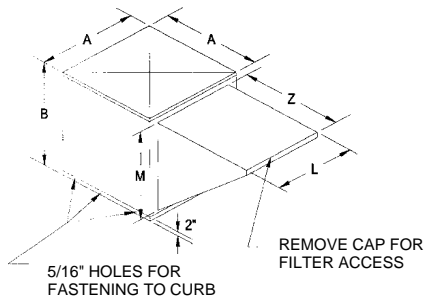

DIMENSIONS (inches)

MODEL	A	B	D	E	F	G	H	L	M	Z	FILTER SIZE (QTY.)	* INSIDE CABINET	UNIT WT. (LBS.)
SIS-9	24-3/8	19-3/8	10-1/4	11-13/16	6-9/32	7-1/16	7-1/16	19-1/4	16-9/16	21-1/4	16 x 24 x 1 (1)	24x24	70
SIS-10	28-3/8	21-3/8	11-3/8	13-1/8	7-5/8	8-1/2	8-1/2	20-1/2	18-9/16	25-3/4	15 x 20 x 1 (2)	28x28	87
SIS-12	32-3/8	24-5/8	13-7/16	15-5/8	8-1/16	9-3/8	9-3/8	25-3/8	21-9/16	30-3/4	20 x 25 x 1 (1) & 16 x 25 x 1 (1)	32x32	117
SIS-15	36-3/8	28-3/8	15-7/8	18-5/8	8-1/2	7-3/4	12-5/16	31-3/16	25-13/16	33-1/2	20 x 28-1/2 x 1 (2)	36x36	175
SIS-18	36-3/8	42-1/2	18-7/8	21-7/8	7-1/4	6	11-1/2	35-5/8	32-11/16	40-1/4	20 x 25 x 1 (2) & 16 x 25 x 1 (2)	36x36	262
SIS-20	44-3/8	49	24-3/4	24-3/4	9-13/16	14-7/16	5-3/16	38-5/8	35-9/16	45-1/2 **	20 x 25 x 1 (6)	44x44	497

* CURB SIZE TO BE SMALLER THAN INSIDE CABINET SIZE TO ALLOW FOR FLASHING AND ROOFING

** INCLUDES FILTER SECTION.

NOTE: WT. SHOWN IS LESS MOTOR AND DRIVE